

# Refrigerated Display Cases Fudzi for Promotions

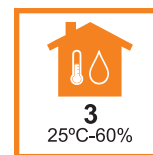

## CHARACTERISTICS:

Refrigerated display case Fudzi was designed as a universal advertising spot combining design and functionality.

Height and tilt adjustable, this display case is suitable for promotions and presentations of new products, and shockproof transparent sidewalls accentuate the buyer's look at the goods.



Shelves in PF models can be mounted on different heights and give the opportunity to use all the area of display case for display of goods without deteriorating the overview.

## STANDARD COLOR OPTIONS:

gray&steel



**SPECIFICATIONS:**

Model	Length with sidewalls, mm → mm	Length without sidewalls, mm → mm	Horizontal exposure area, m <sup>2</sup> 	Useful volume, m <sup>3</sup> 	Working temperature, °C 
PF11-13 VM 1,25-2	1280	1250	1,93	0,21	0...+4
PF11-12 VM 1,25-2			1,56	0,17	
PI11 VM 1,25-2			1,06	0,11	
PG11 VM 1,25-1			1,06	0,11	

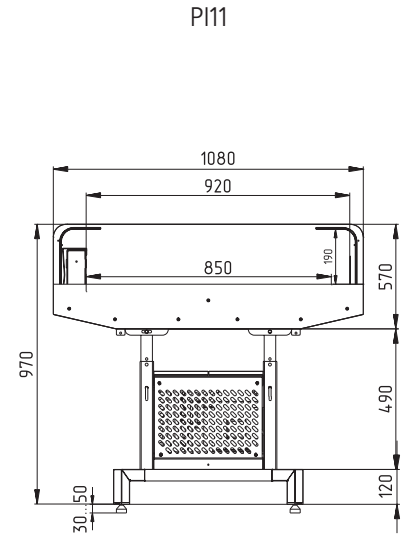
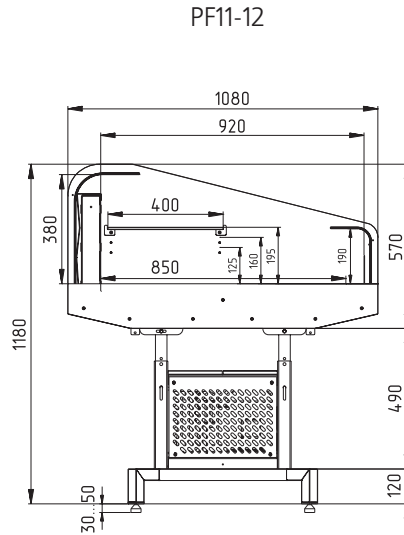
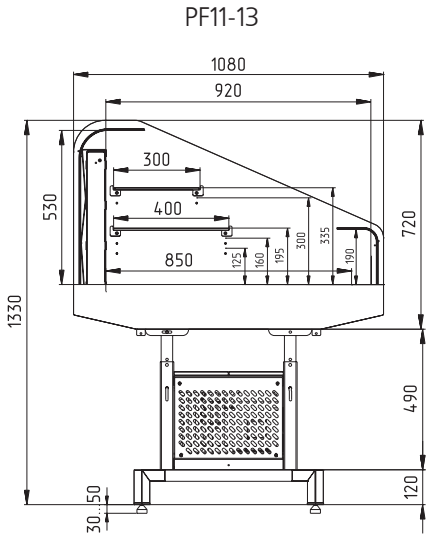

**OPTIONS:**

- Line docking
- Protective bumper
- Wheel support
- Price holders

